

# BFM® Guidelines - TR Connectors

The BFM® TR (Tool Release) Connector was developed for applications where the connector is mounted very close to equipment that is rotating or spinning very fast. There are some applications where it is mandatory to have a connector fitted so that a tool must be used to remove the connector.

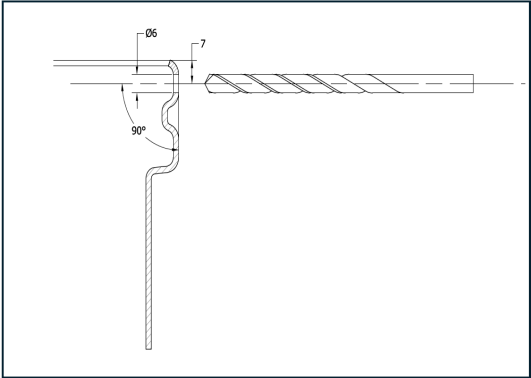
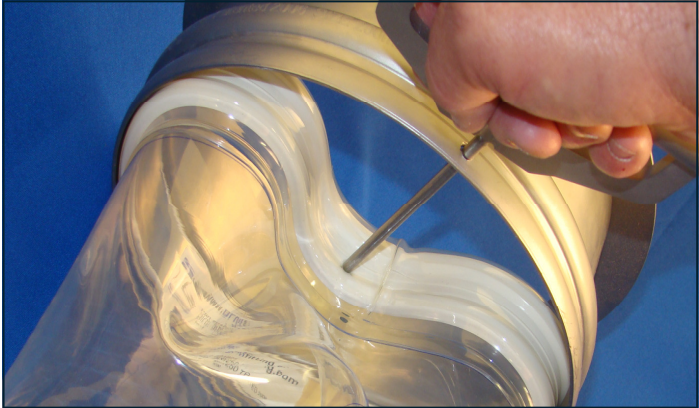

The Snap Ring of the BFM® TR connector is manufactured to have a firmer fit than a standard connector. Once a BFM® TR connector is fitted, it can only be removed by using a TR Release Tool, which is simply inserted into a 6mm hole in the side of both the upper and lower spigots.

A 6mm hole is drilled in a standard spigot in the position shown above.

Another very popular way of ensuring safety while using the BFM® fitting near rotating machines is to use a proximity switch. For more information please ask for the guidelines on Proximity Switches.



It is important to note that the BFM® TR connector fits very firmly in place and that caution must be used when inserting and removing the connectors. Fingers must be kept away from between the spigot and the connector. Please note the instructions on the following page.

**BFM Global Ltd**  
PO Box 66-087  
Beach Haven, Auckland 0749, New Zealand  
Email: sales@BFMfitting.com  
www.BFMfitting.com



## INSTALLATION



**STEP 1**  
Ensure the BFM® spigot is clean and dry.



**STEP 2**  
Seat the back of the connector into the BFM® spigot and release. The cuff will snap into the spigot.

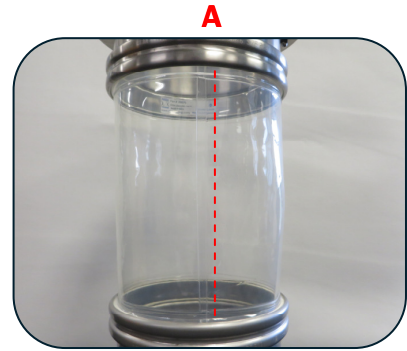

**STEP 3**  
Snap into the second spigot ensuring that the welded seam of the connector is straight and that points A and B are directly in line.

## CAUTION !

IT IS IMPORTANT ON THE TOOL RELEASE FITTING TO KEEP YOUR FINGERS CLEAR OF THE SEAL AS IT SNAPS INTO PLACE WITH FORCE.

## REMOVAL



**STEP 1**  
Insert the removal tool in the opening of the hole and push towards the centre of the fitting.



**STEP 2**  
Hold the seal of the connector and remove from the spigot.

BFM Global makes no warranty of any kind, expressed or implied, except that goods sold shall be of merchantable quality, free of manufacturing defect, and the buyer assumes all risk and liability resulting from the use of the goods, whether used singly or in combination with other products.

**BFM Global Ltd**  
PO Box 66-087  
Beach Haven, Auckland 0749, New Zealand  
Email: sales@BFMfitting.com  
www.BFMfitting.com

 **BFM**®  
fitting  
“Keeping You Connected”